

SDRAM (8MB TO 32MB)

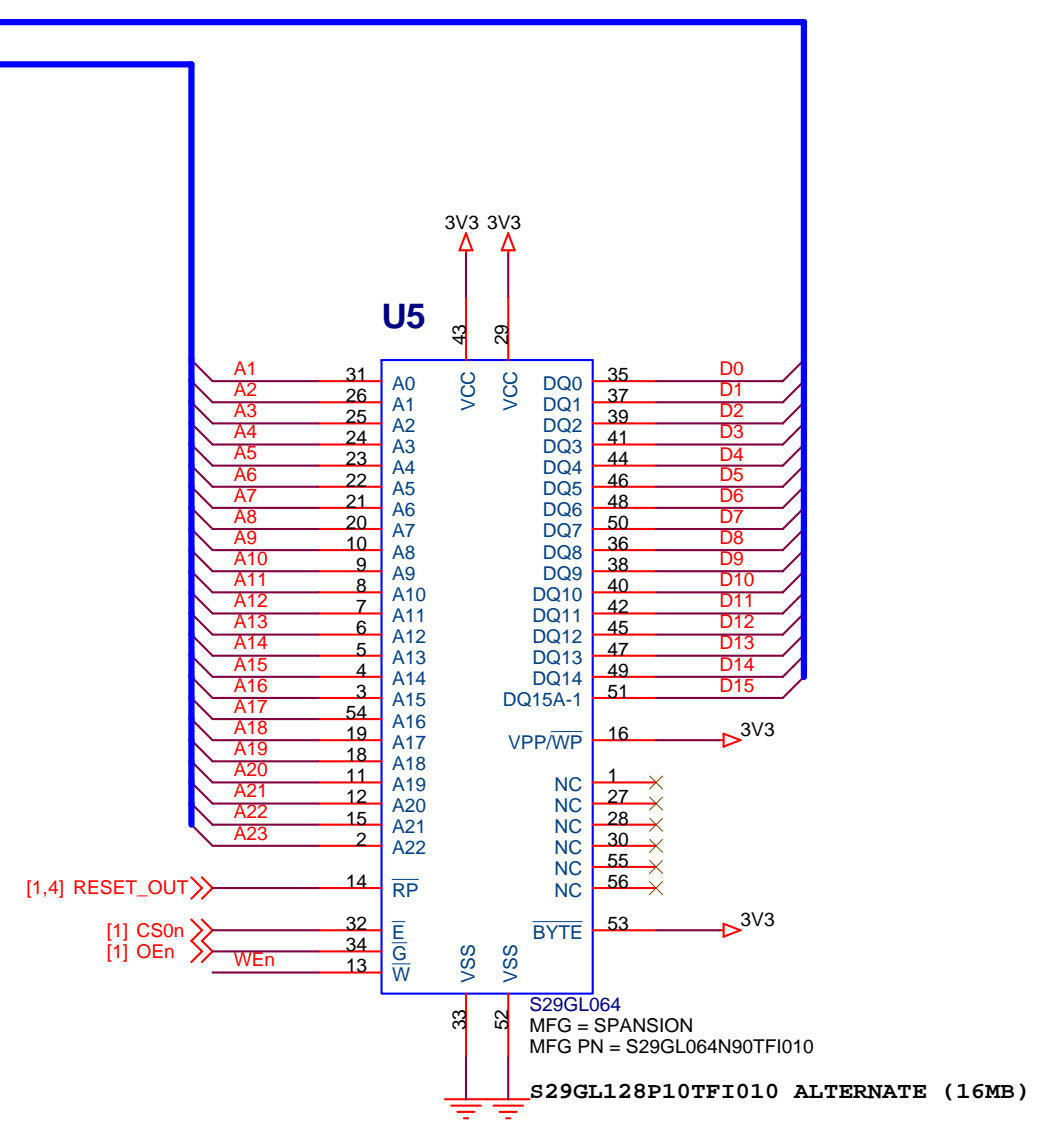

NOR FLASH (8MB TO 16MB)

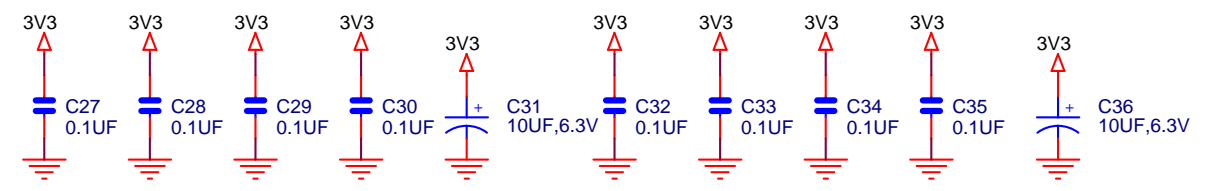
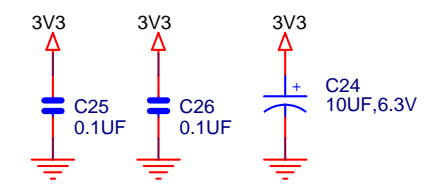

FUTURE DESIGNS, INC. 2702 TRIANA BLVD HUNTSVILLE, AL 35805		FDI
Title SDRAM FLASH		
Size B	Document Number UEZGUI 7.0"	Rev 1.2
Date: Thursday, October 21, 2010	Sheet 2	of 5

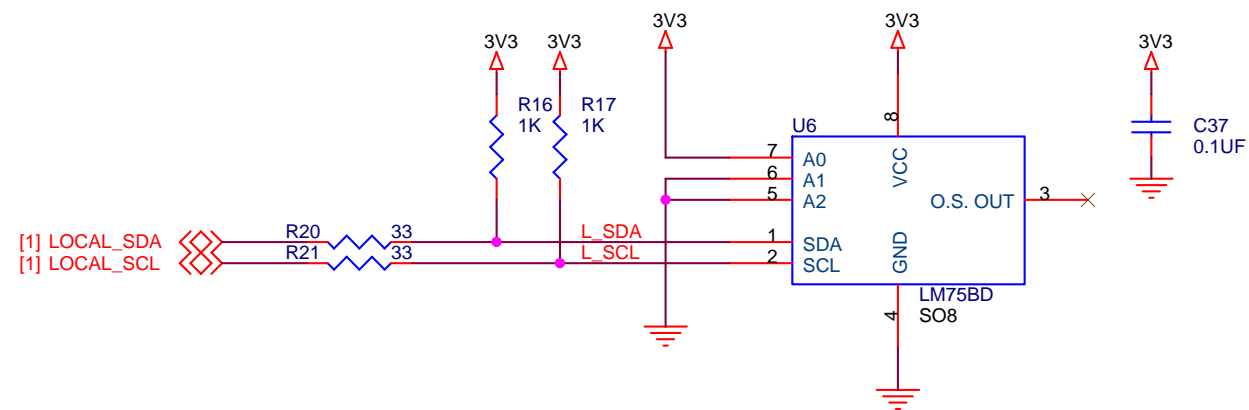

TEMP SENSOR

I2C ADDRESS = 0x92
 Range & Accuracy: +/- 2 C from -25 C to 100 C
 +/- 3 C from -55 C to 125 C

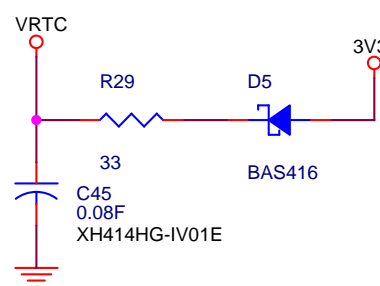

SUPERCAP

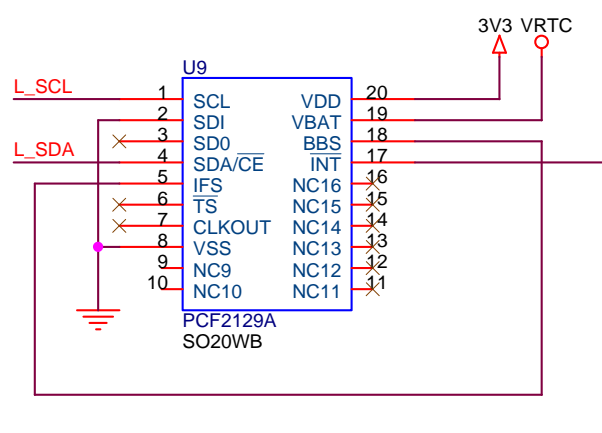

REALTIME CLOCK

I2C ADDRESS = 0xA2

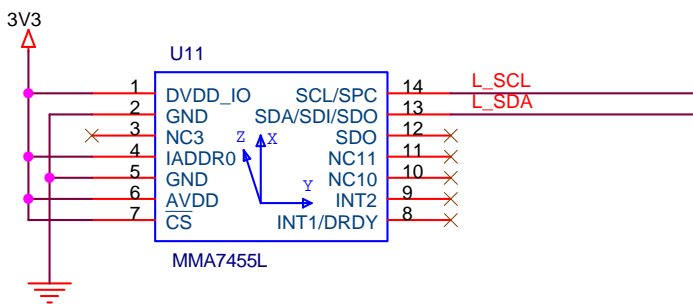
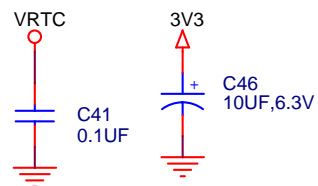

3D ACCELEROMETER

I2C ADDRESS = 0x1D

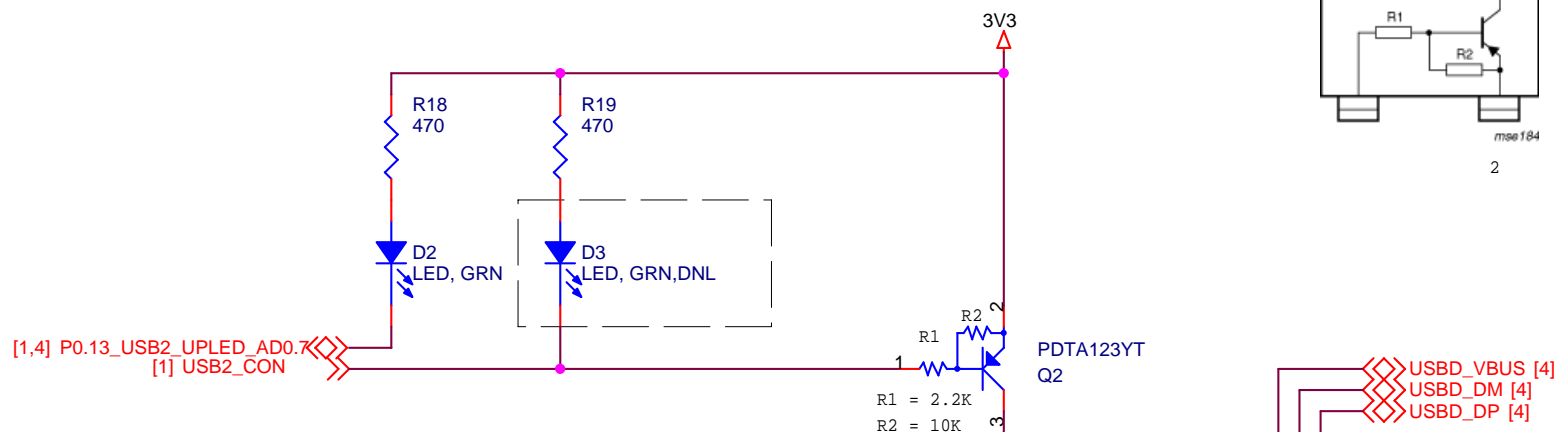
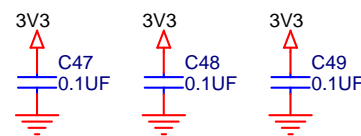

SOFTCONNECT FOR REENUMERATION

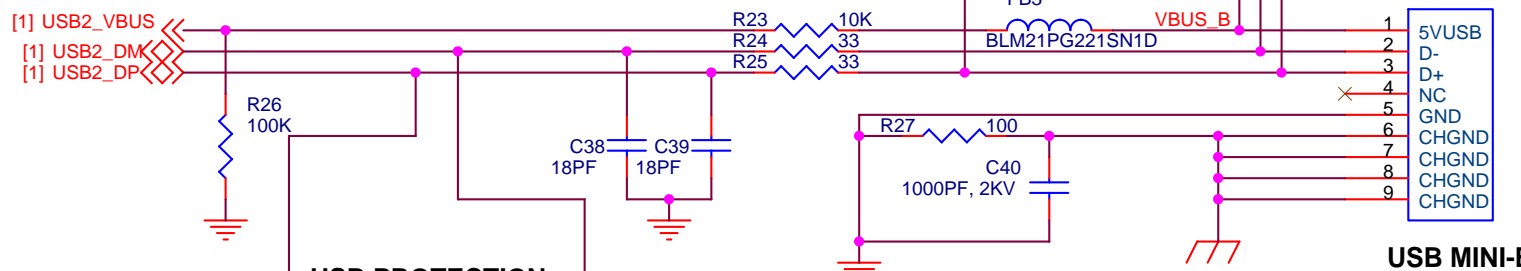

USB DEVICE

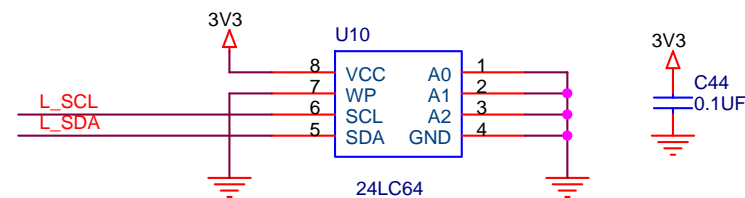

EEPROM (64Kb)

I2C ADDRESS = 0xA0

FUTURE DESIGNS, INC. 2702 TRIANA BLVD HUNTSVILLE, AL 35805		FDI
Title	USB DEVICE I2C PERIPHERALS	
Size B	Document Number UEZGUI 7.0"	Rev 1.2
Date:	Thursday, October 21, 2010	Sheet 3 of 5

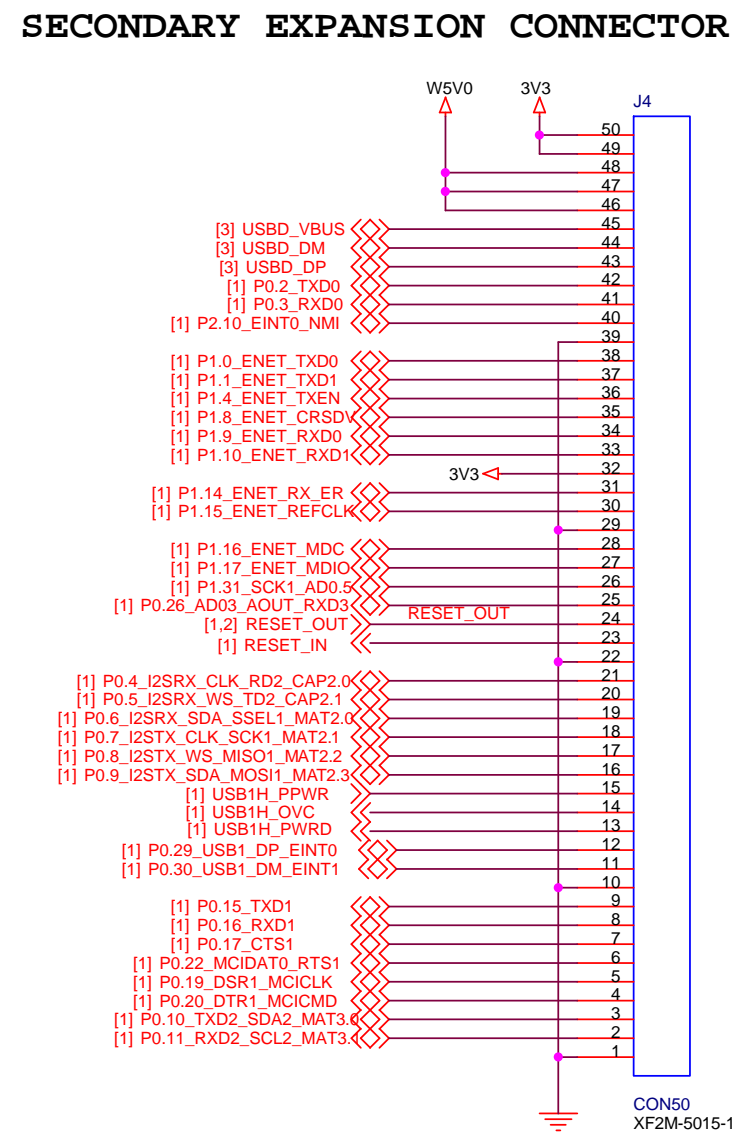
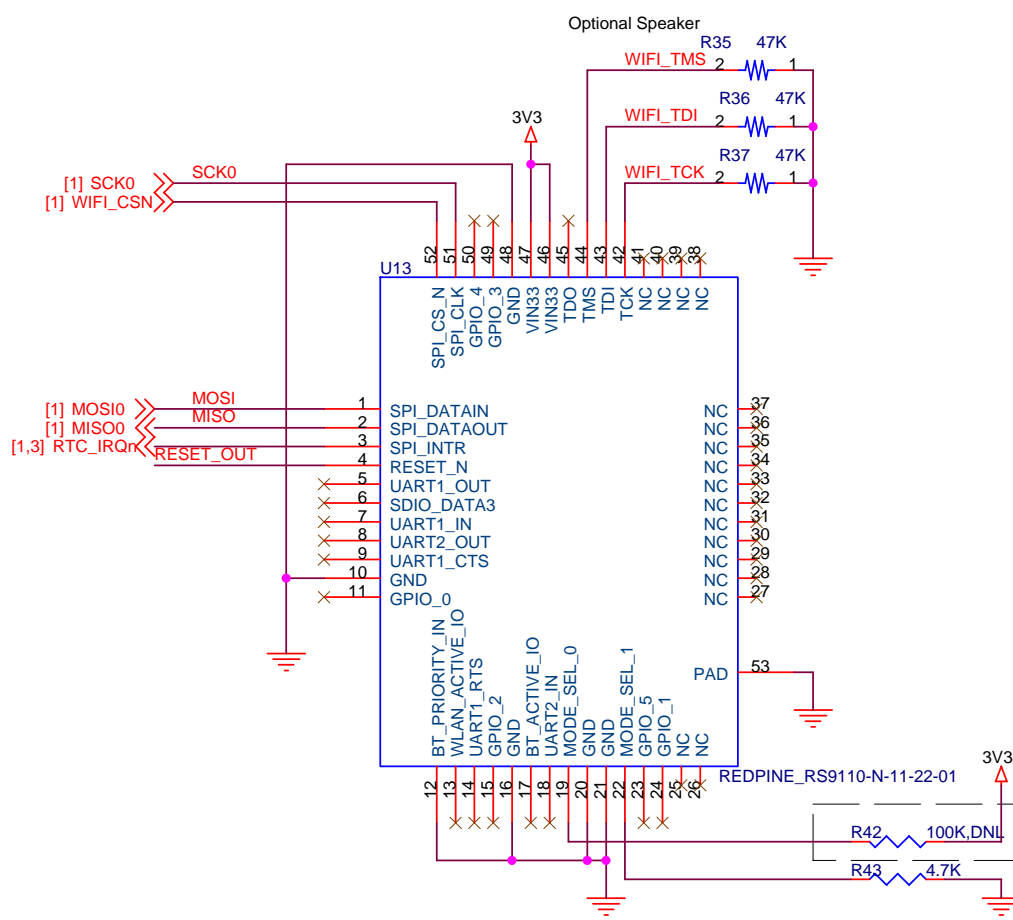
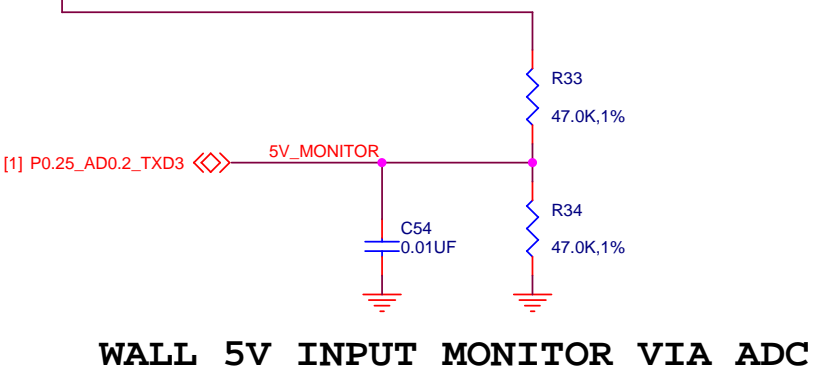
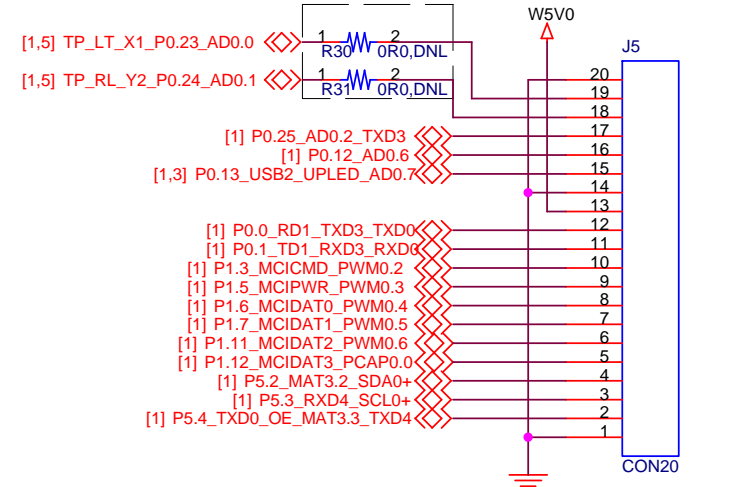
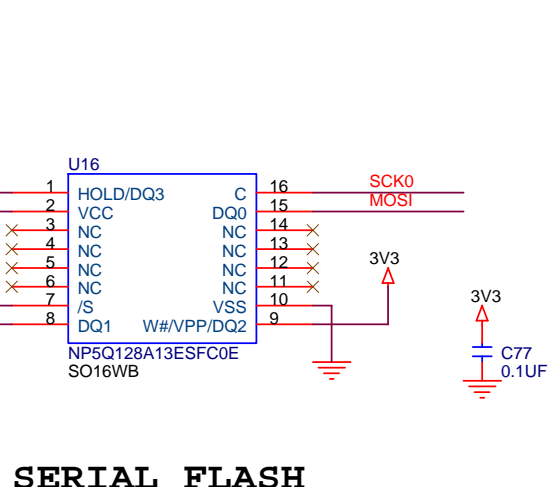
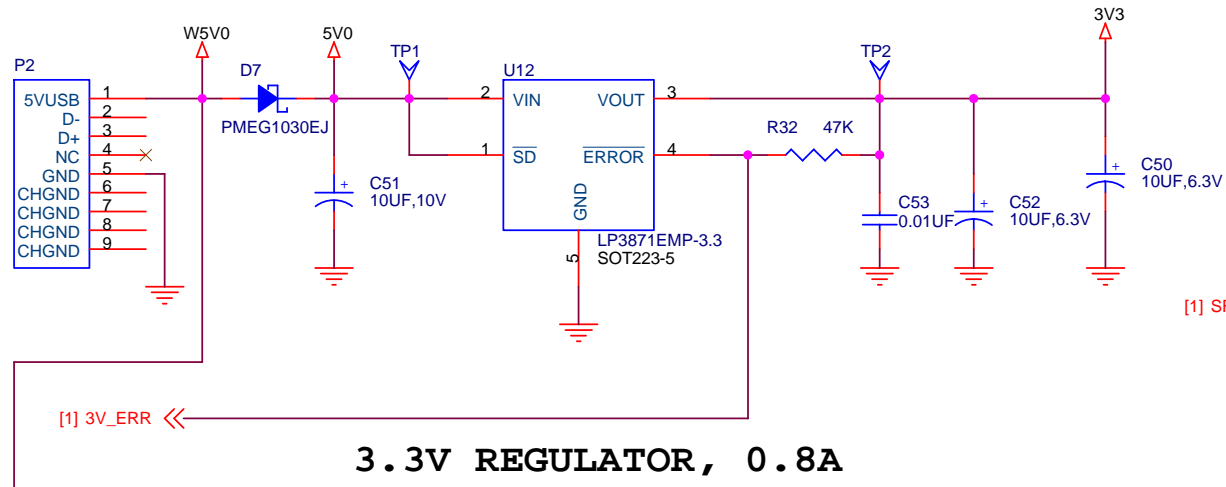

WALL 5V INPUT MONITOR VIA ADC

SERIAL FLASH

SECONDARY EXPANSION CONNECTOR

SPEAKER
16 OHM, 2.4KHZ

REDPINE WIFI MODULE

PRIMARY EXPANSION CONNECTOR

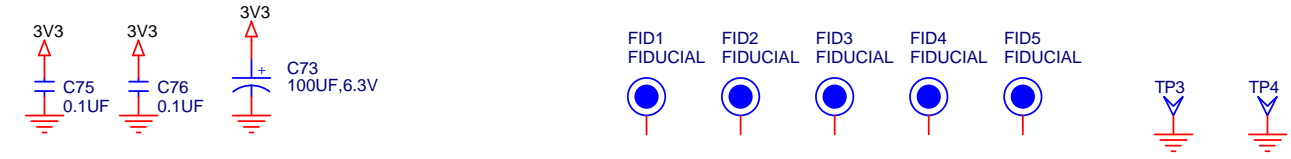

FUTURE DESIGNS, INC. 2702 TRIANA BLVD HUNTSVILLE, AL 35805		FDI
Title: VREG IO CONN WIFI SPKR		
Size: Document Number UEZGUI 7.0"	Date: Thursday, October 21, 2010	Rev: 1.2
Sheet: 4 of 5		

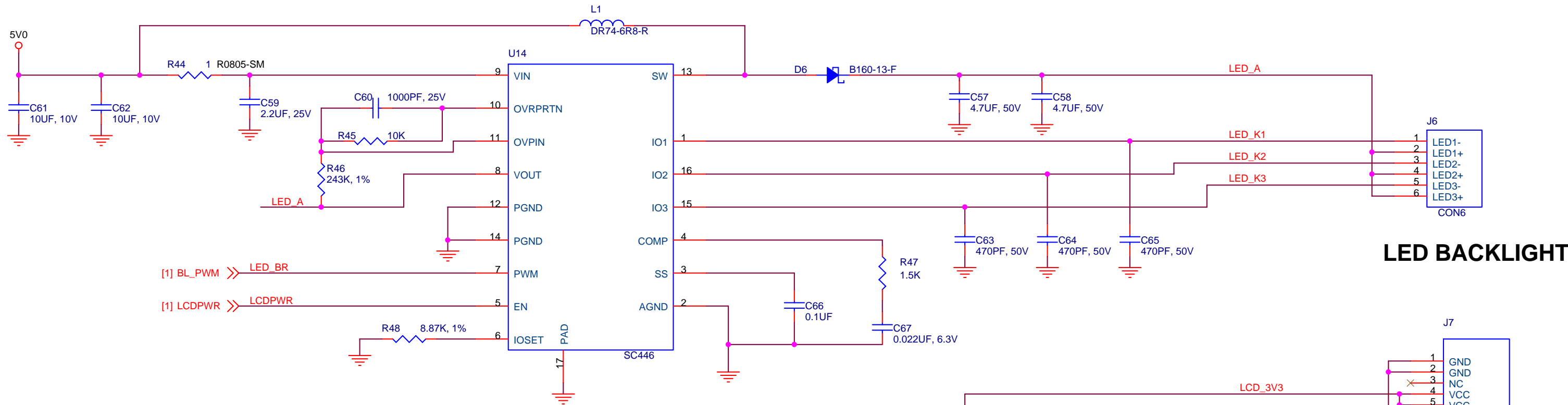

BACKLIGHT GENERATOR

LED BACKLIGHT

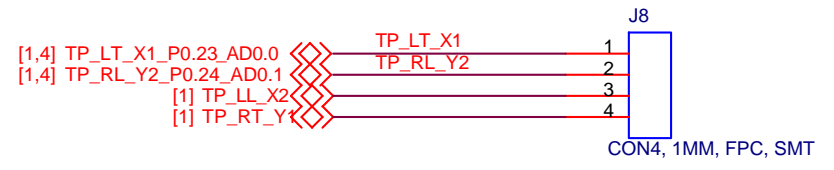

TOUCH PANEL

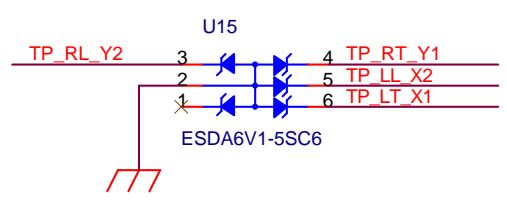

TP ESD PROTECTION

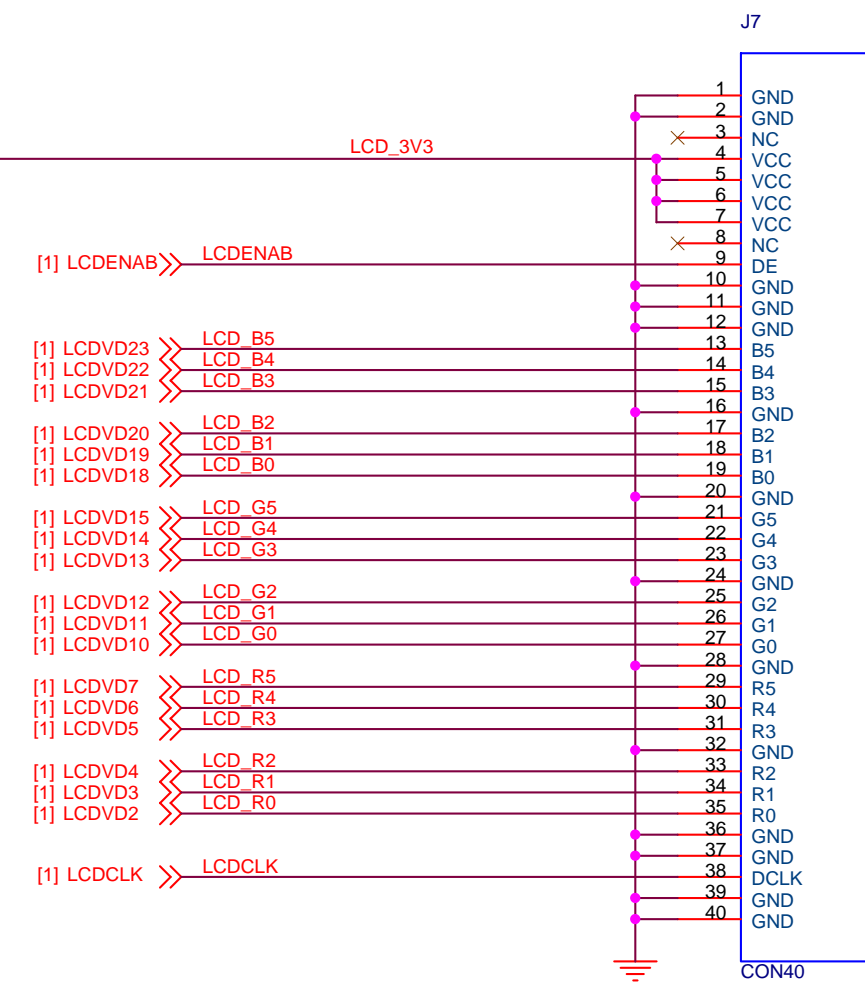
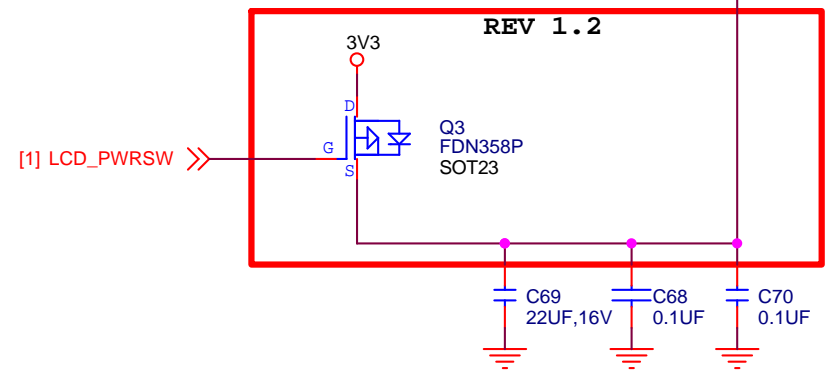

7.0" LCD

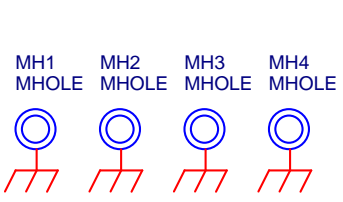

FUTURE DESIGNS, INC. 2702 TRIANA BLVD HUNTSVILLE, AL 35805		
Title	LCD TP BL	
Size	Document Number	Rev
B	UEZGUI 7.0"	1.2
Date:	Thursday, October 21, 2010	Sheet 5 of 5