

RESET

RIGHT ANGLE SMT SO THAT
PAPERCLIP MAY RESET THROUGH
PINHOLE

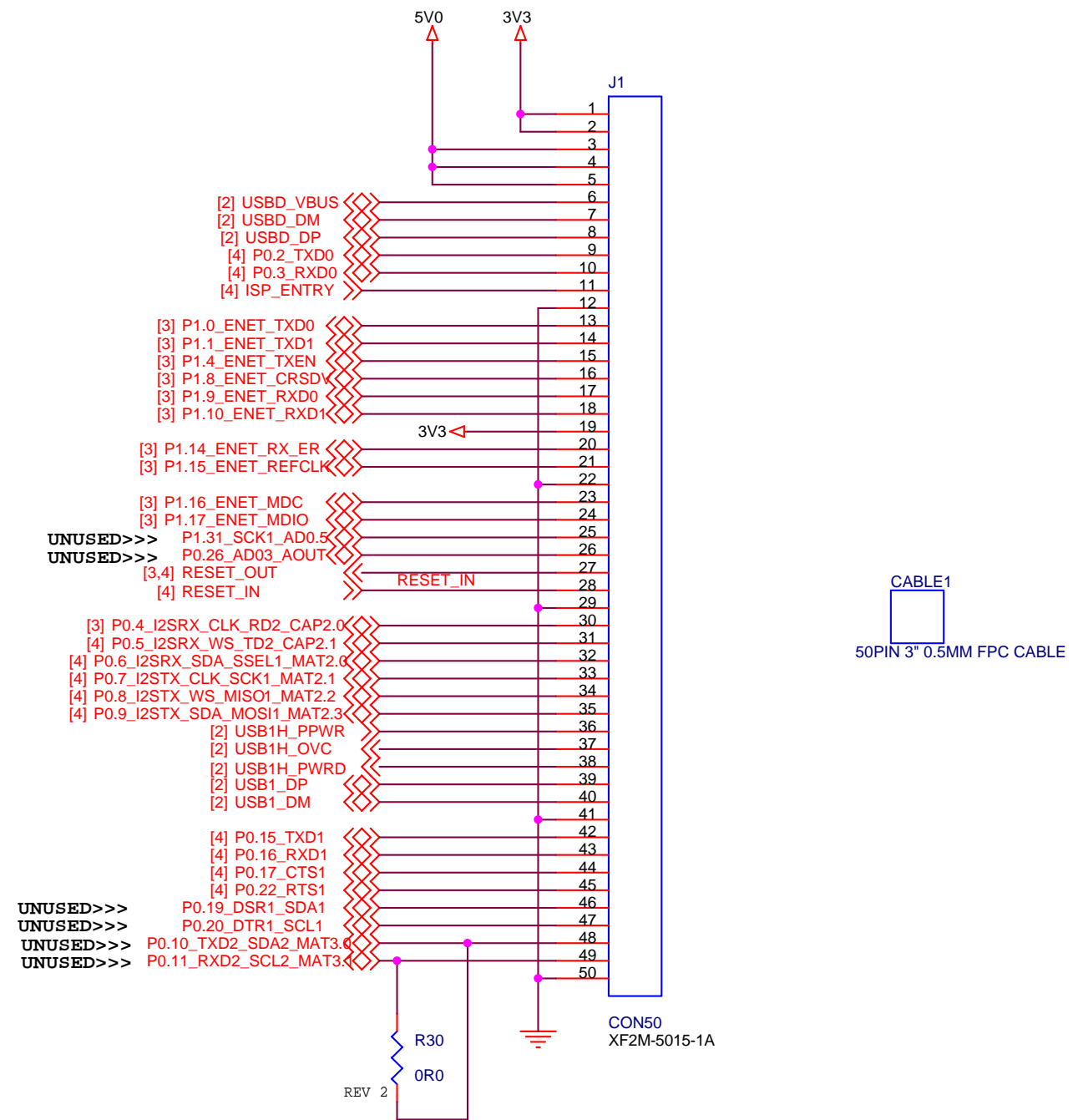
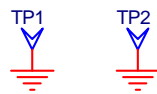
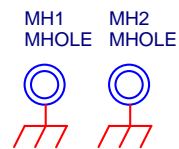
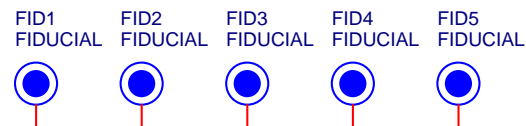

NOTE: PINOUT IS MIRRORED IMAGE TO MAIN BOARD SINCE FPC CABLE IS DIRECT CONNECT, FACE-TO-FACE (PIN 1 OF CONNECTORS IS OPPOSITE FROM EACH OTHER)

FUTURE DESIGNS, INC. 2702 TRIANA BLVD HUNTSVILLE, AL 35805		FDI
Title uEZGUI EXPANSION BOARD 1		
Size B	Document Number uEZGUI_EXP1_SCH_2.DSN	Rev 2
Date:	Wednesday, December 01, 2010	Sheet 1 of 5

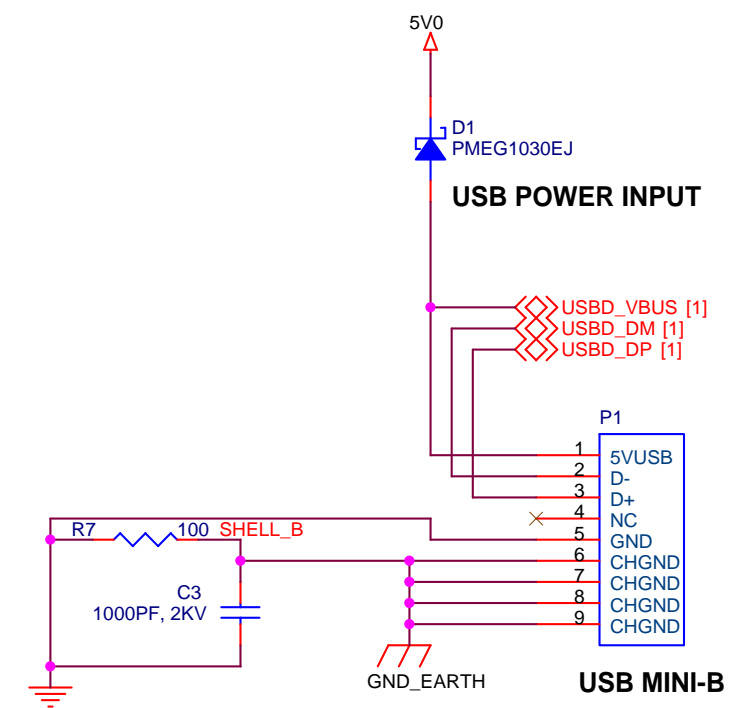
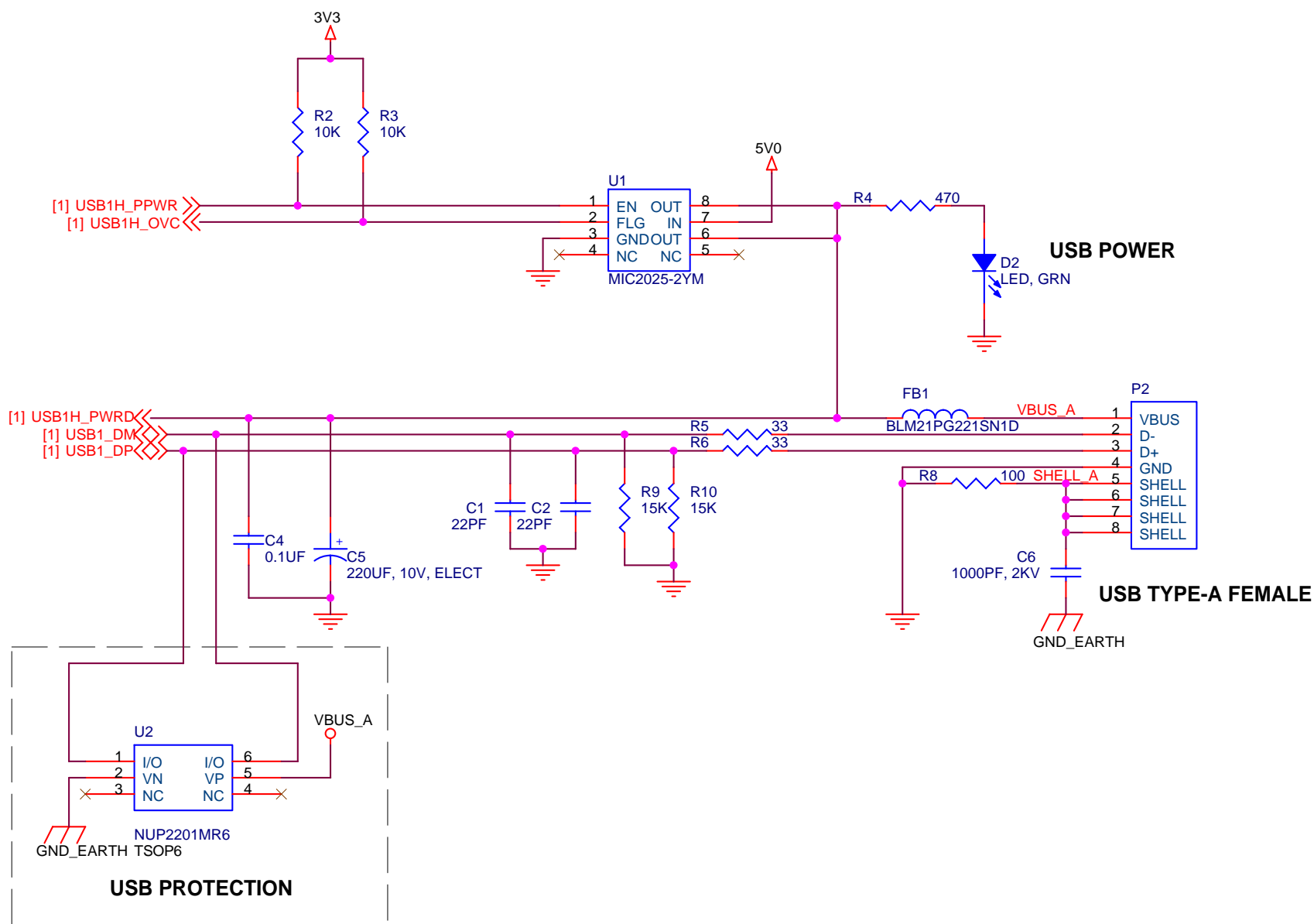

USB DEVICE (PARALLEL WITH UEZ GUI BOARD)

FUTURE DESIGNS, INC. 2702 TRIANA BLVD HUNTSVILLE, AL 35805		FDI
Title: uEZGUI EXPANSION BOARD 1		
Size: B	Document Number: uEZGUI_EXP1_SCH_2.DSN	Rev: 2
Date: Wednesday, December 01, 2010	Sheet: 2	of 5

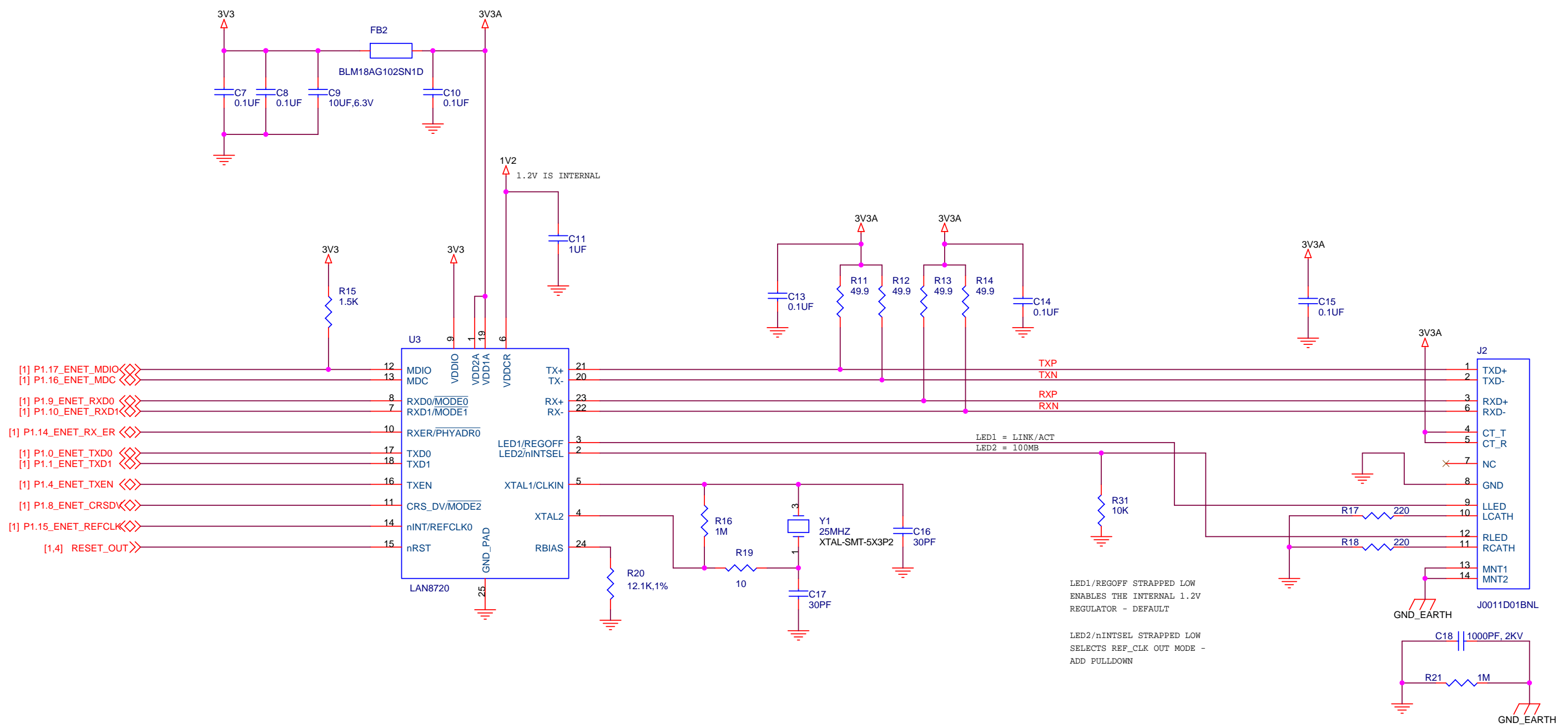

ETHERNET

LED1/REGOFF STRAPPED LOW
 ENABLES THE INTERNAL 1.2V
 REGULATOR - DEFAULT

LED2/nINTSEL STRAPPED LOW
 SELECTS REF_CLK OUT MODE -
 ADD PULLDOWN

FUTURE DESIGNS, INC. 2702 TRIANA BLVD HUNTSVILLE, AL 35805		FDI
Title: uEZGUI EXPANSION BOARD 1		
Size: Document Number	uEZGUI_EXP1_SCH_2.DSN	Rev: 2
Date: Wednesday, December 01, 2010	Sheet: 3	of 5

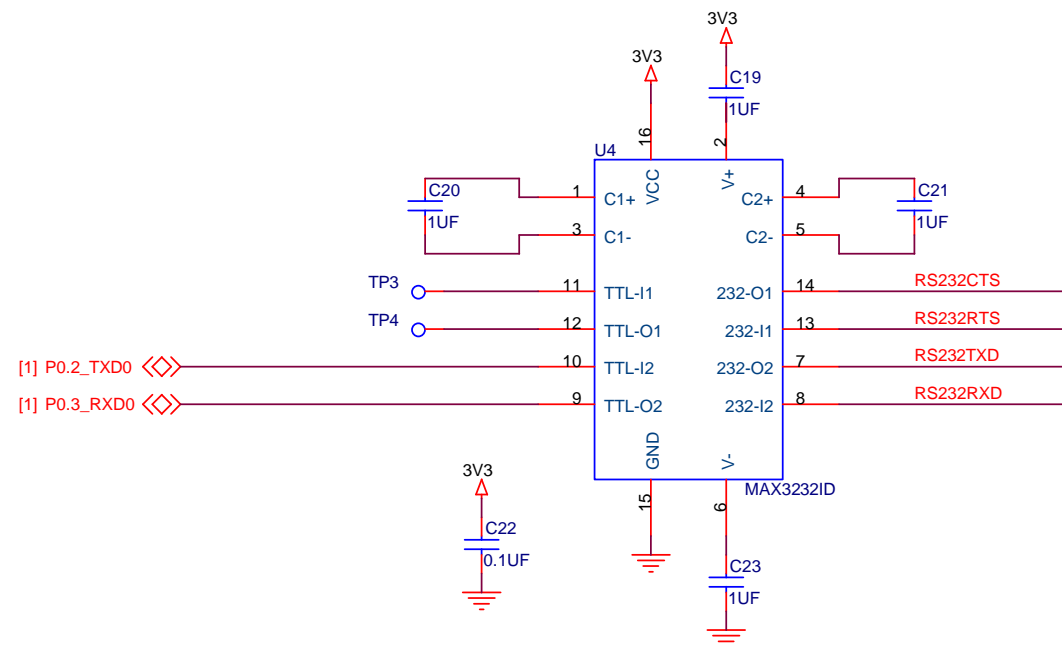

RS232 PORT (UART0)

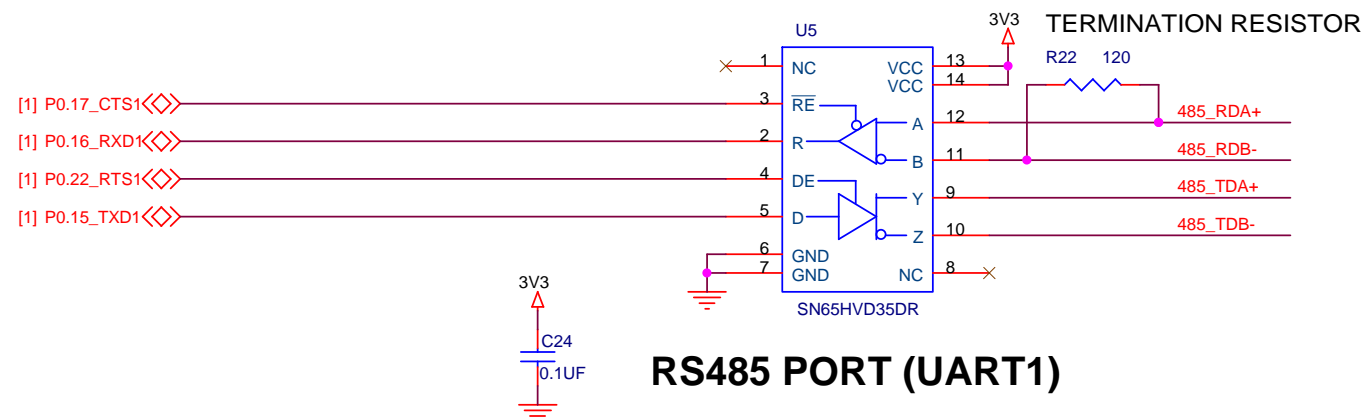

RS485 PORT (UART1)

**JUMPER 1-2 FOR RS232 ON UART0
JUMPER 2-3 FOR RS485 ON UART1**

DEFAULT 1-2

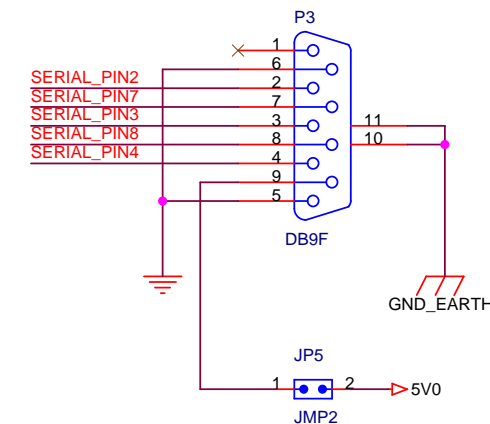
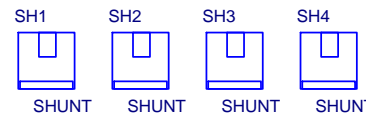
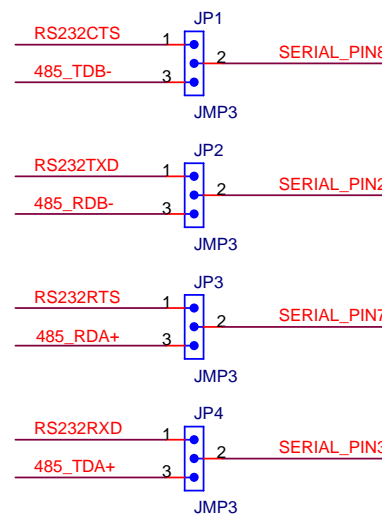

JUMPER HERE FOR POWER THROUGH DB9 (IN OR OUT) TYPICALLY FOR RS485 OPERATION

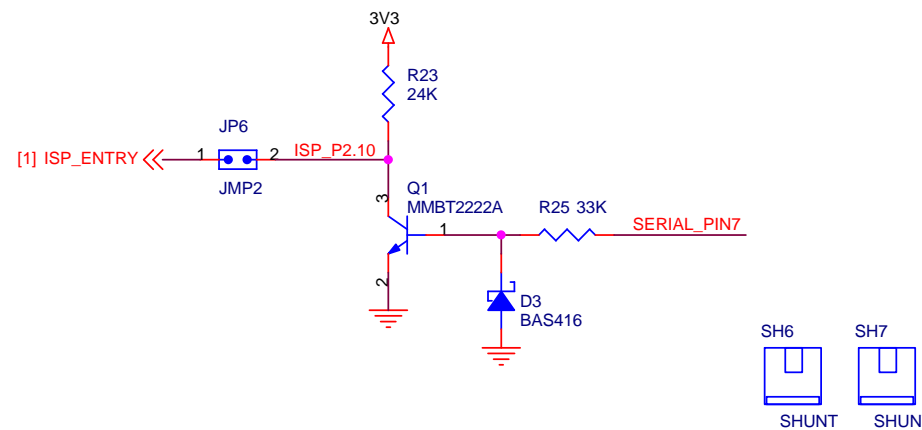
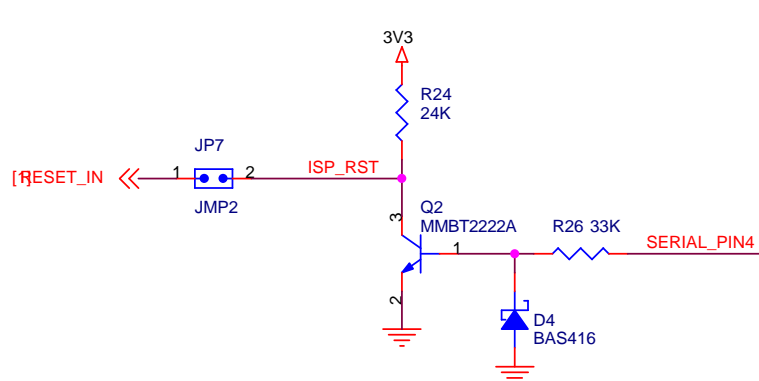

**ISP CONTROL CIRCUITRY
JUMPERS JP1-JP4 MUST BE IN RS232 (UART0) SETTINGS
JUMPERS JP6 & JP7 MUST BE SHORTED
DEFAULT OPEN**

FUTURE DESIGNS, INC. 2702 TRIANA BLVD		FDI
Title: uEZGUI EXPANSION BOARD 1		
Size: Custom	Document Number: uEZGUI_EXP1_SCH_2.DSN	Rev: 2
Date: Wednesday, December 01, 2010	Sheet: 4	of 5

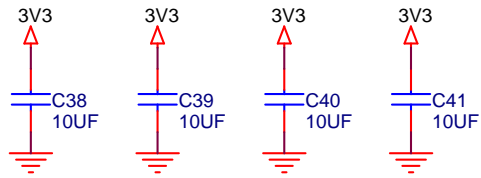
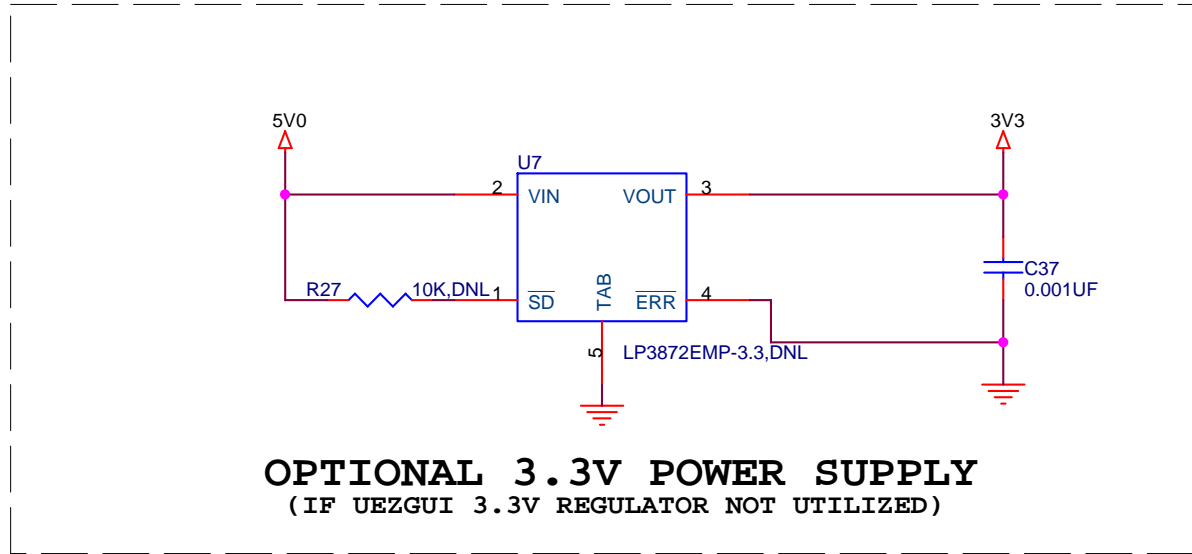
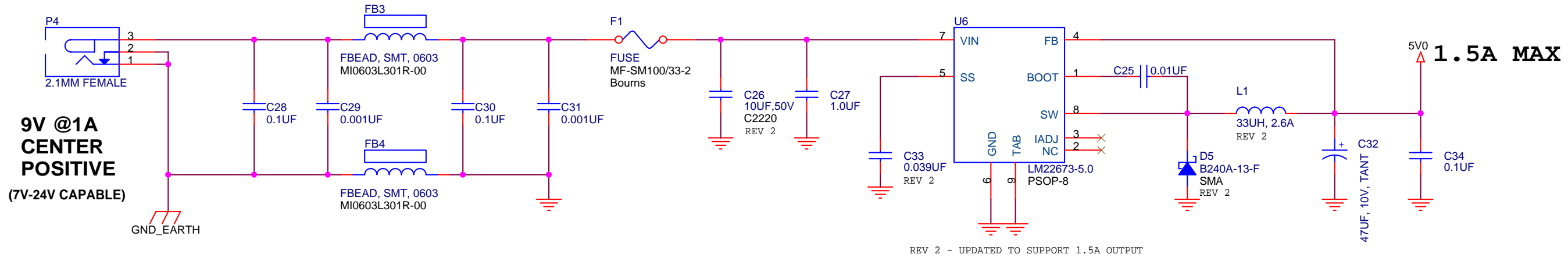

M1
AC Adapter, 9V 1A DC REG

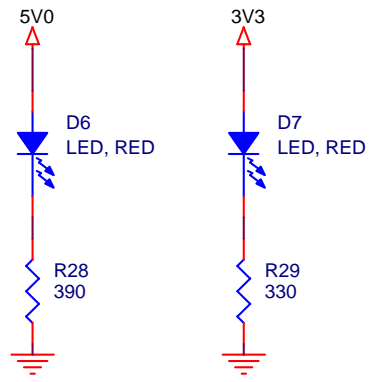

FUTURE DESIGNS, INC. 2702 TRIANA BLVD HUNTSVILLE, AL 35805		FDI
Title uEZGUI EXPANSION BOARD 1		
Size	Document Number uEZGUI_EXP1_SCH_2.DSN	Rev 2
Date:	Wednesday, December 01, 2010	Sheet 5 of 5